

# radiant panel bathroom heaters

## the Apollo range

The unique Apollo range of radiant panel bathroom heaters provides the ultimate in bathroom heating.

Combining the benefits of high comfort radiant panel heating with the added convenience of fixed rails for drying and airing towels, Apollo is the ideal solution where towel drying and full room heating are required from a single appliance.

Incorporating highly accurate electronic thermostatic control, Apollo can be used stand alone or as part of an integrated whole-house system controlled by Dimplex pilot wire or mains borne signalling multi-heater programmers.

## Range features

- Compact, stylish casing with distinctive curved grille.
- Two fixed towel hangers (not heated).
- Highly comfortable radiant heat output, reducing heat stratification and energy wastage.
- Fitted with an electronic thermostat, accurate to within 0.1°C to maintain a stable room temperature.
- User selectable comfort, background and frost protection settings.
- Splash proof (IPX4 rated) for use in bathrooms and wet areas.
- Controls cover which can be locked if necessary.
- Compatible with Dimplex single or 4 zone multi-heater programmers.



Model APL100

# technical specifications

## Electronic Control

Dimplex electronic panel heaters feature highly accurate electronic thermostats, providing superior comfort and operating efficiency. As the room temperature nears the desired set point, power to the elements is reduced, and the room temperature closely monitored to an accuracy of less than 0.3°C, minimising overshoot and temperature drift, resulting in better energy-efficiency and user comfort.

Being electronic, control is totally silent and reliable – performance will not deteriorate even over many year's use.

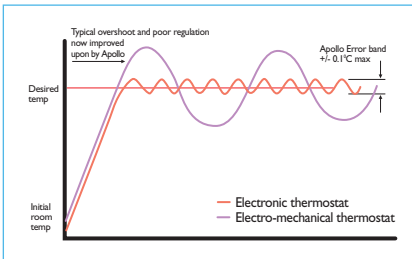

## Controls

### 1 Function control

User selection of "comfort", "background" (4°C below the thermostat setting) and "frost protection" (5°C), off and programmed operation (if programmer is fitted). Neon indicator shows function selected.

### 2 Thermostat Dial

The dial is marked \* to 9. The \* setting represents a room temperature of approximately 5°C and may be used for protection against frost. The other settings range up to a maximum room temperature of approximately 35°C. A neon indicator shows when the element is operating.

### 3 Plug-in control modules

A range of optional plug in control modules are available for use with Calidou:

- Single zone pilot wire programmer (RX9911) controls up to 20 slave heaters linked via pilot wire. Provides 7 day control, switching heater between comfort and setback mode. Can be removed from heater for easy programming.

- Single zone mains borne signalling programmer (RX9912) controls multiple slave heaters, with RX9913 MBS receivers fitted to each slave. Provides 7 day control, switching heater between comfort and setback modes.

See page 24-26 for full details on the range of plug in control modules.

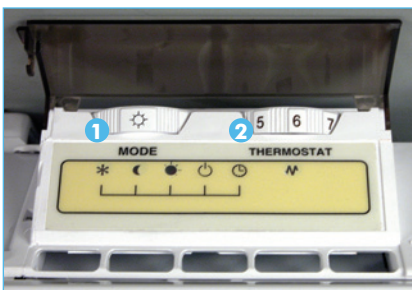

## Main and Fixing Dimensions

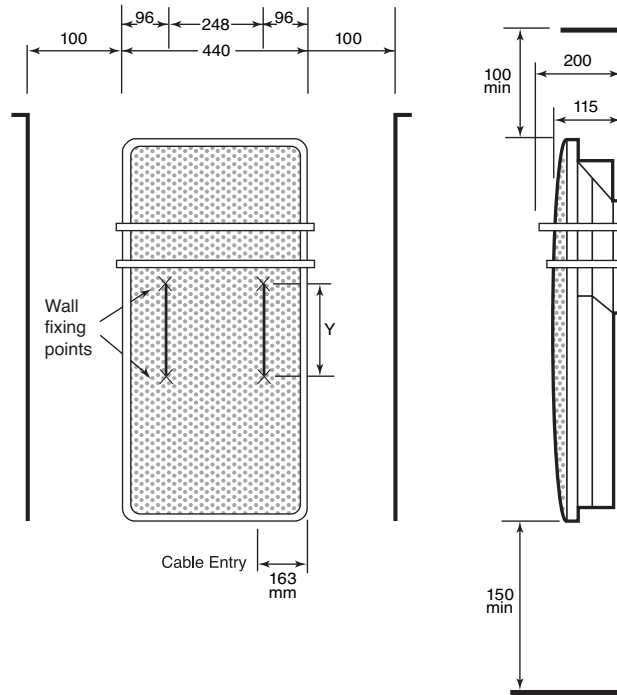

Model No.	Loading	Height	Width	Y	Weight
APL100	1.0kW	830mm	440mm	468mm	7.2kg
APL150	1.5kW	1040mm	440mm	618mm	9.3kg

## Multi Zone Control

Compatible with Dimplex 4-zone pilot wire and mains borne signalling controllers (RX9913 receivers for MBS systems).

## Elements

Two mineral filled sheathed electric elements are embedded in aluminium heating plates. Low element operating temperature of around 200°C reduces air drying effects and dust burning. The heating plates have a unique design – the forward face is finished in matt black and has greater surface area to maximise radiant heat. The reverse side is in its natural smooth aluminium state to minimise heat loss to the wall. The design provides an even temperature across the front panel, using the whole surface area available and maximises the throw of radiant heat into the room.

## IP Rating

Splash-proof IPX4 for use in wet areas.

## Construction

Durable polyester powder coated steel with mesh steel front grille.

## Installation

A detachable wall-mounting frame allows quick wall fixing.

## Electrical Connections

2m 4-core cable (live, neutral, earth and pilot wire) supplied fitted to each heater.

## Colour/Finish

White.