

# hydronic base unit heaters

## the BUH range

The hydronic BUH range is designed specifically for use on 'wet' heating systems. Small and compact, the BUH fits discreetly into the base of kitchen units, reception desks, shop counters and even stair risers.

The BUH will heat a room much faster than a traditional radiator many times its size, but will not occupy valuable wall space.

## Range features

- Maximum output of 2.0kW (6824 Btu/h).
- With choice of low and boost settings.
- Automatic low temperature cut out thermostat.
- Fan only option for cool air circulation (boost or normal speed).
- Supplied with a choice of brown, white or stainless steel grilles to suit any plinth unit.



Model BUH195

## Colour Options



Stainless steel (model shown BFH24TS)

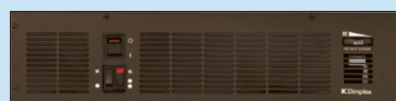

Brown (model shown BFH24TB)

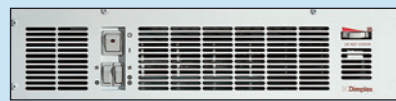

White (model shown BFH24T)

**Note:** Above grille close ups are for colour reference only. For actual grille please refer to main photography of BUH195.

# technical specifications

## Controls

Built-in single pole winter/summer switch and two position boost/low switch. Low temperature cut-out thermostat set at 38°C. Facility for fan only operation.

## Connections

Pre-wired with 2m 3 core electrical cable. Supplied with flexible hoses and isolating valves to connect the unit's copper pipes to the flow and return pipes of the central heating system.

## Finish

Supplied complete with a choice of stainless steel, powder coated brown or white finishes.

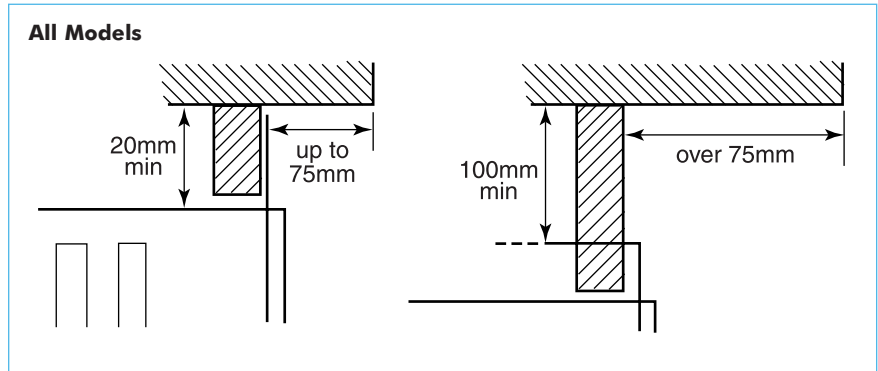

If the overhang above the heater is greater than 75mm, then a distance of at least 100mm must be maintained between the overhang and the uppermost part of the heater.

Model	Fan Speed				Power	Water
	Normal (Btu/h) Watts		Boost (Btu/h) Watts		Consumption Watts	Capacity Litres
BUH19B/W/S	4372	1280	6830	2000	31	0.2

## Installation/Dimensions (mm)

