

technical specifications

Controls

WFC3NB/S

- Variable thermostat, range 5°C to 35°C.
- Function selector switch for Off, Fan Only (low speed), Fan Only (high speed), 1kW, 2kW or 3kW outputs.
- Neon indicator shows mains connection.

WFE3TNB/S

- Variable thermostat, range 5°C to 35°C.
- On/Off switch – heat output is automatically selected (1kW, 2kW or 3kW) dependent on heat requirement.
- 7 day electronic timer. 10 preset weekly profiles with 8 programmable time periods per day, plus manual over ride facility.

Construction

Pressed steel front panel and base.

Colour/Finish

WFC3NB/WFE3TNB: black stove enamelled body with cherry effect end panels.

WFC3NS/WFE3TNS: satin silver enamelled body with black painted end panels.

Elements

One 2000W and one 1000W helically wound fully strung open coil element.

Fan

Very low noise tangential fan.

Airflow (max) 22 litres/sec (79.2m³/h).

Safety protection

Auto reset over temperature cut out.

Installation

Keyhole mounting slots in rear panel.

Electrical

Cable not supplied. Designed for flexible cable connection to the fixed wiring of the premises.

For a copy of our new, more detailed commercial brochure, please ring Customer Care on 0845 600 5111

General Dimensions

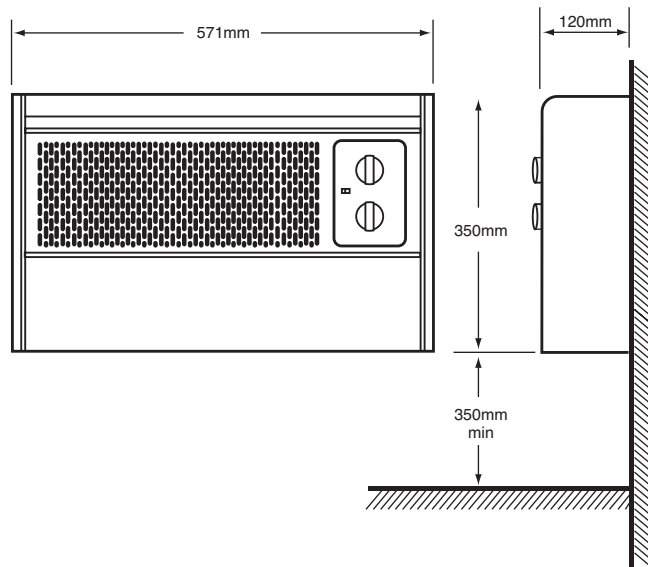

Fixing Dimensions

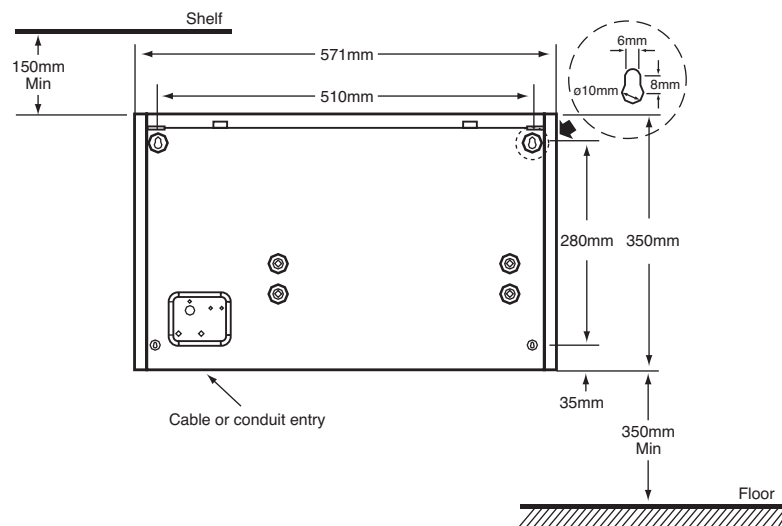

Model	Loading	Length	Height	Depth	Weight
WFC3NB WFC3NS	3.0kW	575mm	347mm	120mm	6.6kg
WFE3TNB WFE3TNS	3.0kW	575mm	347mm	120mm	6.6kg