

slimline storage heaters

manual & automatic
input controls

the XL and XLS ranges

The UK's slimmest and most popular storage heaters offer performance, economy, ultra slim design and maintenance free reliability.

The XL and XLS are suitable for a wide range of domestic and commercial applications. The heating level of XL range is adjusted by means of a variable input control, which the occupant sets in line with the changing weather conditions.

The automatic XLS range offers improved comfort, economy and ease of use, with a sophisticated automatic charging system to ensure the level of charge is adjusted to compensate for changing weather conditions without the need for user intervention. At the heart of this system is the patented Twin Sensor^{®*}, which meets the requirements of Building Regulations Part L1, which requires all electric storage heaters installed in new build to be fitted with automatic charge controls.

Range features

- Less than 150mm (6" deep).
- Smooth curved styling.
- XL range features manually adjustable charge regulator to control the amount of heat stored during the charge period.
- XLS range features automatic charge regulator, which automatically adjusts the level of input charge to compensate for changing weather conditions without user intervention.
- Running cost savings of up to 15% can be achieved using automatic controller compared to manual static storage heaters.
- Room temperature boost control increases heat output when required and may be used automatically or manually.
- Easy to use controls, out of sight of young children.
- Frontal grille for efficient heat distribution.
- Secure wall fixings for safety.
- Feet may be fitted under carpet or on top of a suitable floor covering.
- Matches the PLX range of panel heaters.
- Compatible with all off peak tariffs.
- Drip proof construction (IPX2 rated).
- See page 36 for accessories.

BUILDING REGULATIONS
PART L COMPLIANT†



Model XLS12



Storage heater with shelf

technical specifications

Construction Details

Galvanised finish sheet steel base, mounted on steel feet, supporting double skin front and outer panels. One piece front panel/grille assembly and front inner skin remove for brick loading.

Internal Details

1 Storage Core

Material: High density bonded magnetite bricks.

2 Heating Element

Type: Incoloy sheathed in units of 850W.

3 Thermal Insulation

Type (a) Front and Rear Panels – microporous silica.

Type (b) Top and Ends – resin free mineral wool.

Type (c) Base – calcium silicate slab.

4 Supply Connection

Located at front right hand end of base – accessible by removal of front panel assembly. Hidden cable support straps at rear of heater allow neat supply cable connection from either side of heater.

5 Assembly

Remove front panel assembly then front inner skin. Remove internal packing containing elements, position rear layer of bricks, heating elements, and front layer of bricks.

Controls

The control knobs are positioned on the sloping rear top panel of the heater, and are therefore out of sight of young children. The knobs incorporate a cross bar and raised pointer for ease of operation.

1 Charge Controller – XL

Type: Bi-metal, adjustable from zero charge to fully charged condition

2 Charge Controller – XLS

Type: Hydraulic close differential room temperature sensing thermostat with external sensor.

3 Thermal Safety Device

Type: Bi-metal – manual reset.

4 Damper Control

Type: Bi-metal strip, selection variable from early to late or zero boost.

Model	Dimension A	No. of slots
XL12/XLS12	542mm	4
XL18/XLS18	770mm	5
XL24/XLS24	998mm	6

Packing

1 Case Assembly

Containing assembled heater case and heating elements. Packed in single carton. XL12/XLS12 Model – approx. weight 20kg. XL18/XLS18 Model – approx. weight 26kg. XL24/XLS24 Model – approx. weight 32kg.

2 Storage Bricks

Supplied in packs of 2. Approx weight of brick 7.5kg each.

IP Rating

Drip-proof IPX2.

Finish

Front panel, sides and top panel – Willow White; rear heat shield, wall spacer and grille – contrasting Birch Grey.

Shelf

An attractive shelf is available in 3 lengths. (See page 28 for photograph).

Accessories

Please refer to page 36 for details of optional accessories.

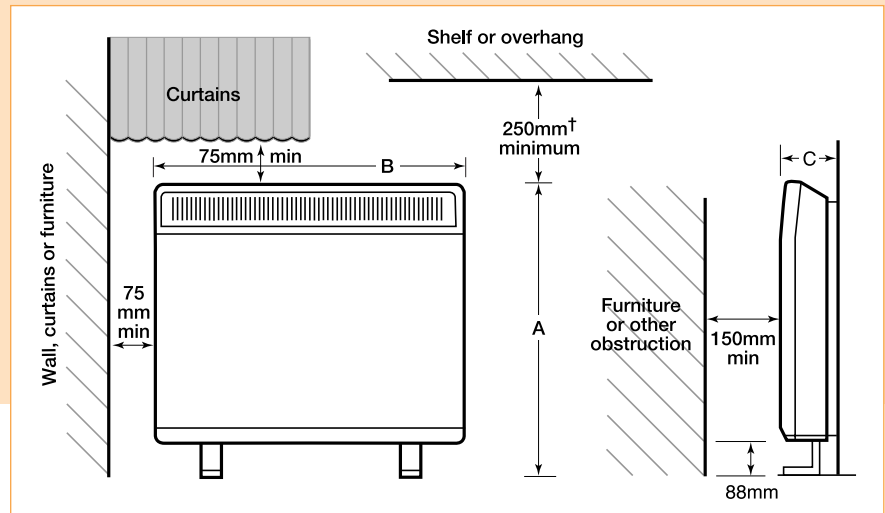
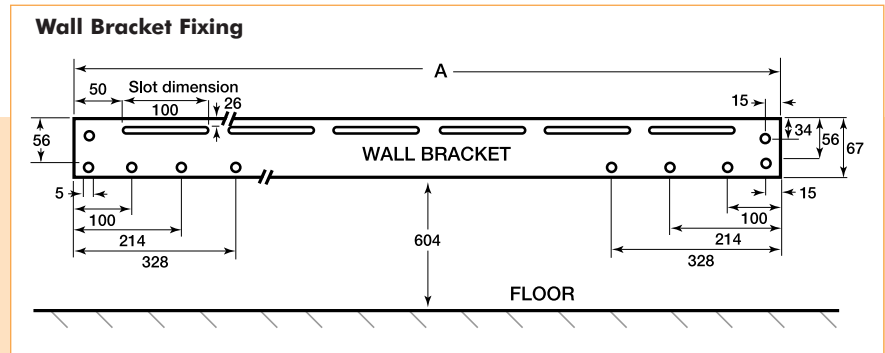

Model	XL12/XLS12	XL18/XLS18	XL24/XLS24
Performance Input rating	1.70kW	2.55kW	3.4kW
Charge Acceptance (7hr continuous)	11.9kWh	17.85kWh	23.8kWh
DIMENSIONS			
Height (A)	706mm	706mm	706mm
Width (B)	565mm	793mm	1021mm
Depth (C)	146mm	146mm	146mm
Weight	76kg	109kg	144kg
Shelf Model No.	SHE12	SHE18	SHE24