

## DIMENSIONS

### 25F SuperChill

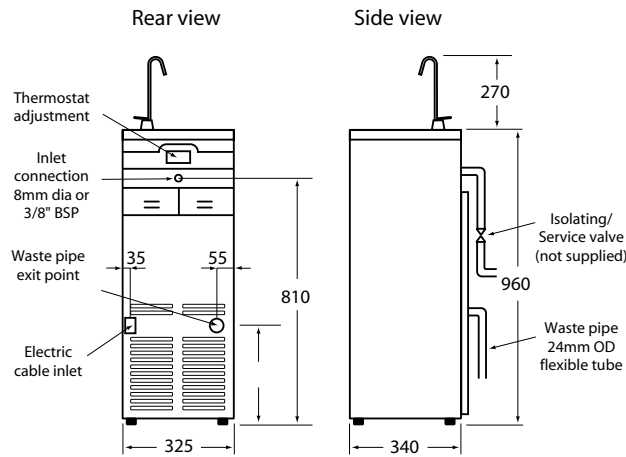

### 25W SuperChill

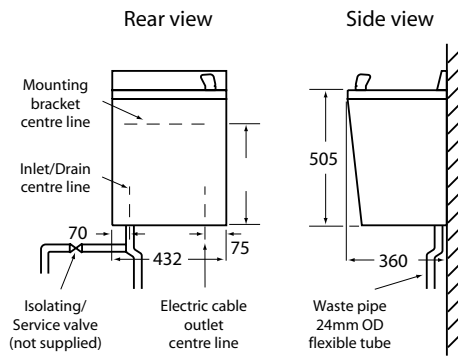

### 30B SuperChill

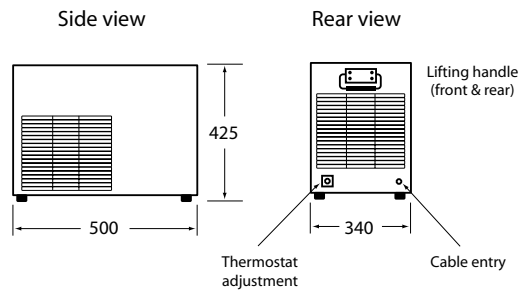

## SPECIFICATION AND ORDERING GUIDE

SuperChill model	Mounting	Electrical Rating @ 240V	Chilled Water Output Litres/Hour	Nominal Water Outlet Temperature (°C)	Weight empty (kg)	Weight full (kg)	Rated Pressure (bar)	Product Code
25F	FLOOR	207W	25	10	29	34	3.5	95:200:225
25W	WALL	207W	25	10	26	27	3.5	95:200:226
30B	BUILT-IN	207W	30	10	29	32	3.5	95:200:227

## ACCESSORIES

Cup Holder	95:970:127
Drip Tray (for use with 30B Built-in model)	95:970:123
Pressure Reducing Valve	95:970:352