

VENT-AXIA ACM RANGE

All motors are fitted with Standard Thermal Overload Protection. (S.T.O.P.).

Motors are speed controllable on their high speed setting. Designed for ambient temperatures up to +50°C.

Size 100 and 125 with shaded pole motors. Size 150, 200, 250 and 315 with capacitor start and run motors.

All sizes are Class I appliances except ACM200 which is Class II Supply voltage 220-240V/1/50Hz.

Type	ACM100	ACM100T	ACM125	ACM150	ACM150T	ACM200	ACM250	ACM315
Stock Ref. No	171 04 010C	171 04 020E	171 05 010C	171 06 010B	171 06 020C	171 08 010A	171 10 010A	171 12 010A
Amps @ 240V	0.09	0.1	0.12	0.2	0.21	0.8	0.65	1.1
MAX m ³ /h @ FID	220	220	252	460	460	810	852	1860
Watts	18	23	25	42	48	152	140	270
dB(A) @ 3m	20	23	20	35	35	56	55	62
Electronic Cont.	W30 03 10	W30 03 10	W30 03 10	W30 03 10	W30 03 10	W30 03 10	W30 03 10	W30 03 10
Humidity Sensor	56 35 50	56 35 50	56 35 50	56 35 50	56 35 50	56 35 50	56 35 50	56 35 50
Timespan	56 35 19	56 35 19	56 35 19	56 35 19	56 35 19	56 35 19	56 35 19	56 35 19

Dimensions

Size	100mm	125mm	150mm	200mm	250mm	315mm
A∅	97	122	147	197	248	310
B∅	178	178	200	207	253	335
C	124	124	138	135	186	220
D	298	259	350	300	385	455
E	96	96	118	130	156	190
F	168	168	192	140	170	210
G	120	120	162	100	145	182
H	153.5	153.5	178	94	138	178
Weight	2.4kg	2.4kg	2.7kg	4.9kg	9.4kg	12.8kg

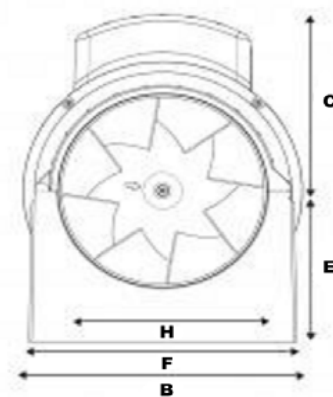
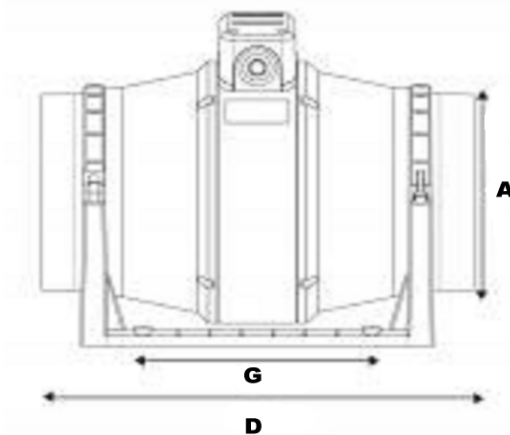

DEALEC

Tel: 01304 215 575