



Features and Benefits

- Powered heat recovery unit for smaller residential or commercial applications up to 160m³.
- Up to 70% heat recovery.
- Meets new Building Regulations.
- Extremely quiet on low speed.
- Low power consumption.
- Effective condensation control.

Model	Stock Ref.
HR200XL	45 68 64

The HR200XL heat recovery unit has been specially designed to provide ventilation for flats or internal rooms in residential, commercial, educational or leisure applications. Balanced ventilation is achieved by using nominal 100mm diameter insulated flexible ducting. The unit is completely self contained and includes two integral centrifugal speed controllable fans plus a high efficiency polymeric heat exchanger.

Using a high performance, polymeric heat exchange cube, together with two powerful fans, the Vent-Axia HR200XL boasts a temperature efficiency of up to 70%. The compact cube interleaves outgoing moist air with incoming fresh air, allowing the heat from one to warm the other without the two air streams mixing. Energy is saved on room heating, with no power being used by the cube itself.

Performance of HR200XL: Up to 175.4m³/h FID. Ideal for installation in the ceilings voids or cupboards.

Typical Specification

Supply and install a HR200XL Wholehouse heat recovery unit as manufactured by Vent-Axia Clean Air Systems, Fleming Way, Crawley, West Sussex, RH10 9YX, Telephone: 01293 44152.

Performance:	m ³ /h	l/s
Maximum ventilation rate	175.40	48.70
N° speed settings	6	

Efficiency: The unit should retain up to 70% of the temperature differential of out going air.

Heat exchanger: should be of a multi plate cross-flow type constructed out of a polymeric plastic with ultra sonic welded joints.

Motor: should be a 240V 50Hz A/C with sleeve bearings, greased for life. It shall operate up to an ambient temperature of 40°C and be fitted with a manual reset thermal overload protective device.

Fan: The fan impeller should be of a forward curved centrifugal type, dynamically balanced.

Controls: The unit should be powered via a remote multi-step transformer that provides a switch gate between a selected slow speed and boost condition. The switch can be a manual or sensor type or a combination of both.

Ducting spigots: The unit should have 4-N° 100mm Ø x 50mm spigots. (Can be converted to flat ducting).

Filter: not fitted.

Condensation: the outlet provided should be 22mm Ø located on the underside of the unit.

Construction: the unit outer case should be a rigid black ABS moulding. The case should split along a horizontal joint to allow maintained access.

Mains electrical supply: 230VAC 50Hz.

Sound Levels:	dB(A) @ 3m
Maximum	35.0

Complies to the following approvals/ directives:

CE and BEAB.

Dimensions (mm)

Weight: 8.5 kg

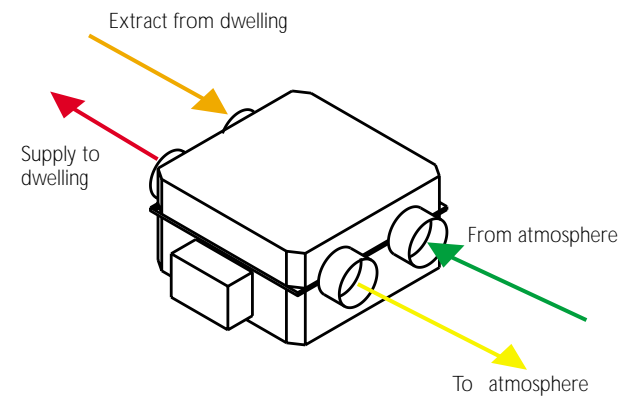
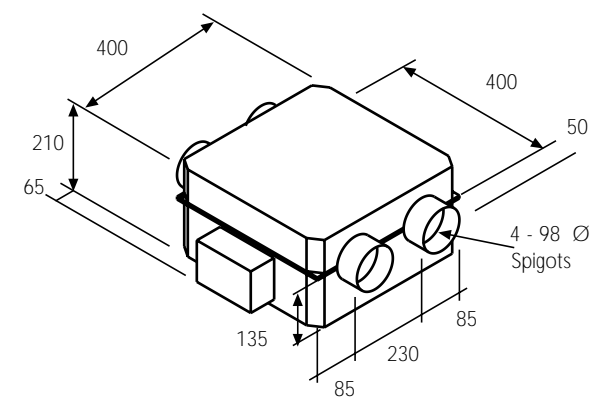

Easy Installation

The Vent-Axia HR200XL is designed for mounting in ceiling voids, lofts or above a suspended ceiling. Four 100mm spigots are provided for simple connection to insulated flexible or rigid ventilation ducting. The unit comes complete with a 22mm condensate outlet.

150VA Transformer



Surface Mounting Transformer with six voltage selections for trickle settings to match dwelling volume. Provides Boost/Trickle ventilation when used with humidity sensors or a manual switch.

Stock Ref: 56 35 38

Power Consumption

Speed	Voltage	Power (W)
Speed 1	80V	32.2W
Speed 2	100V	46.9W
Speed 3	120V	63.7W
Speed 4	140V	80.8W
Speed 5	160V	98.8W
Speed 6	240V	182.1W

Performance

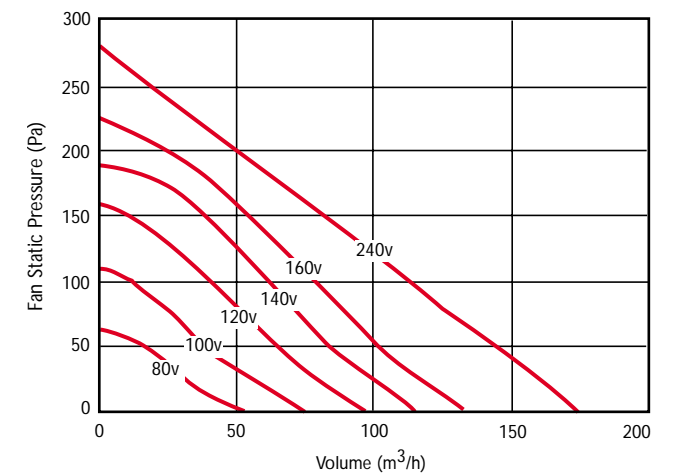

HR200XL to be used with a 150VA Transformer for maximum controllability

Motor Speed	1	2	3	4	5	6
Volume m ³ /h (FID)	55.0	76.8	98.4	116.7	133.6	175.4

Controllers & Sensors

Controller Options					
Trickle Boost Switch	Switch with Neon	Ambient Response Humidistat	Visionex PIR	TIM2	7 Day Timeswitch
45 52 13	45 97 46	56 35 50	45 96 23	37 03 46	56 35 15

For further details on controls & sensors please refer to pages 98-102. For accessories details, please refer to pages 103-105.

For wiring diagrams details please refer to page 120.

COMING SOON.....



HR300XL:

A 4 speed in-line heat recovery unit with a 70% counterflow heat exchanger. A maximum performance of 300m³/h with 4 X 150mm spigots and overall dimensions of 550 x 550 x 292mm.