

**new**

# LoWatt Ventilation - Energy saving solutions

## LoWatt T-Series Wall Model



Extract/intake model in 2 sizes: Size 9 and 12

Long life LoWatt motors last twice as long as conventional motors

Patented electronic shutter system ensures quiet trouble free operation

Up to **80% energy saving**

Designed to comply with International safety standards

Wired or Wire-less fan models available



Behind the newly designed grille of the LoWatt T-Series wall model is a high performance extract/intake ventilating unit designed to fit through most wall thicknesses using the telescopic liner supplied. For walls of exceptional thickness additional liners can be used. Conduit entry is provided for concealed wiring.

### Shutter

LoWatt T-Series models are supplied complete with an integral instantaneous automatic louvre shutter which will operate on both intake and extract and at any angle of mounting.

The shutter is electronically controlled by an actuator with a damped action giving quiet operation during instant opening and closing. The interlocking edges of the shutter blades provide maximum backdraught protection. When the ventilating unit is used with a LoWatt T-Series controller, the shutter can be set open with the fan motor switched Off to provide natural ventilation without the security risk of an open window.

### LoWatt T-Series Controller

The New LoWatt T-Series Controller is a 3 speed surface mounted controller, available in wired or wire-less versions. It offers familiar features such as intake/extract, shutter open and external sensor mode. T-Series LoWatt Controllers are also fitted with an energy saving info button that allows the user to see which function the fan is performing without the need to have the neon lights running constantly.

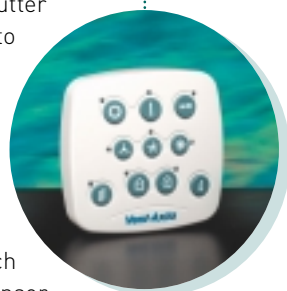

### External brick walls

LoWatt T-Series wall models are designed to fit directly into double brick, solid and cavity walls. The two part telescopic liner accommodates wall thicknesses from 240 to 315mm. For thicker walls additional liner sections are available. LoWatt T-Series wall models are provided with internal and external wall frames which fit flush with both faces of the wall.

### Internal Grille with unit mounted externally

When a more unobtrusive installation is required or access for cleaning is only available from the outside, LoWatt T-Series window models may be installed on a Vent-Axia removable wall fixing plate with an eggcrate grille fitted to the inside wall face.

### New LoWatt T-Series Controller

LoWatt T-Series Controllers are available in both **Wired** and **Wire-less FM** versions. The three speed push button surface mounted controllers provide intake/extract and shutter only options and auto mode position for use with external sensors.

**Wired** versions are connected to the fan using a plug-in Safety Extra Low Voltage 2-core signal cable supplied (10m), allowing simple and safe installation. Alternatively, the **Wire-less FM** controller offers full control without the need for any wiring, ideal for premises where installations need to be carried out with minimum disruption or where surface wiring can be classed as unsightly or obtrusive.

### Sensors - can be used in conjunction with a LoWatt T-Series Controller

**Ambient Response Humidity Sensor** - Self programming electronic On/Off wall mounted humidity sensor which reacts to any rapid increase in humidity and temperature. Night time RH increment setback feature

**Ecotronic Humidity Sensor** - Adjustable set point, solid state controller. Pullcord provides manual override. Adjustable from 65% to 90%RH.

**Air Quality Sensor** - Automatically reacts to the depletion of air quality, sensing tobacco smoke, smells and toilet odours to regulate mechanically ventilated areas

### Dimensions (mm)

Size	A	B	C	D	E	F	Weight kg
230mm	391	388	365	375	143	54	7.77
300mm	470	467	442	450	182	54	10.864

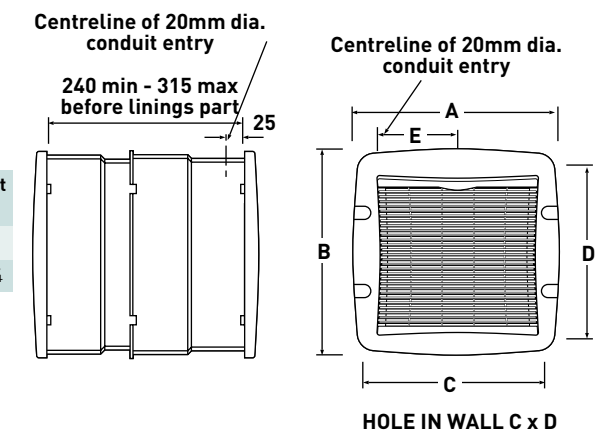

### Performance

Output is for the extract airflow on HIGH.

Unit size	Type	Stock Ref. No. (240V)	Amps @240V	Extract performance			Watts (high)	dB(A) (med) @ 3m
				LOW m³/h	MEDIUM m³/h	HIGH m³/h		
LoWatt TX9WL	Wire-less	<b>45 61 70</b>	0.31	326	562	732	27	39
LoWatt TX9WL		<b>45 61 66</b>	0.31	326	562	732	27	39
LoWatt TX12WL	Wire-less	<b>45 61 78</b>	0.70	660	1355	1650	68	48
LoWatt TX12WL		<b>45 61 74</b>	0.70	660	1355	1650	68	48

**Recommended controller:** Wire-less Controller Stock Ref. No. **45 58 74**  
Wired Controller Stock Ref. No. **45 58 73**

