

WALL OR CEILING-MOUNTED CENTRIFUGAL EXTRACTOR FANS, WITH IPX4 PROTECTION SUITABLE FOR DUCTED INSTALLATION.

VORT PRESS® LL HABITAT RANGE

LONG LIFE

30.000 h

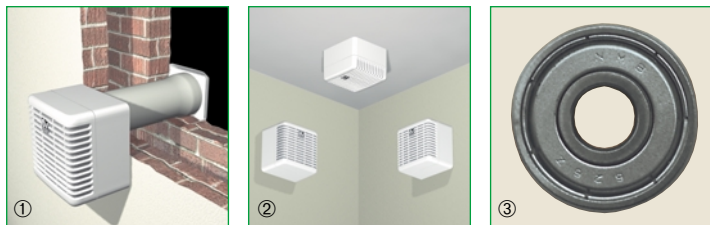

- For continuous ventilation with boost facility. Ideal for use in public sector houses in bathrooms, showers, toilets, utility rooms and kitchens.
- Two models.
- Motor with ball bearings (guaranteed 30,000 hours of continuous operation) with thermal cut-out.
- Two speed motor.
- Double motor-fan housing, anti-vibration supports and backdraught shutter for silent operation.
- Complies with the CEI EN 60335-2-80 standards and IPX4 protection, CEI EN 60529 (Code IP).
- Low power consumption.
- Metallic filter which can be removed and washed (dishwasher safe)
- Fully comply with F1 Building Regulations, plus 1.9D alternative approaches.

Design: F. Trabucco - M. Vecchi

Accessories

(description and data on page 91)

Spare Parts

- Metallic anti-dust filter (30/90: code 1193006019 - 45/135: code 1193006021).

Wiring diagrams shown on page XXXIV.

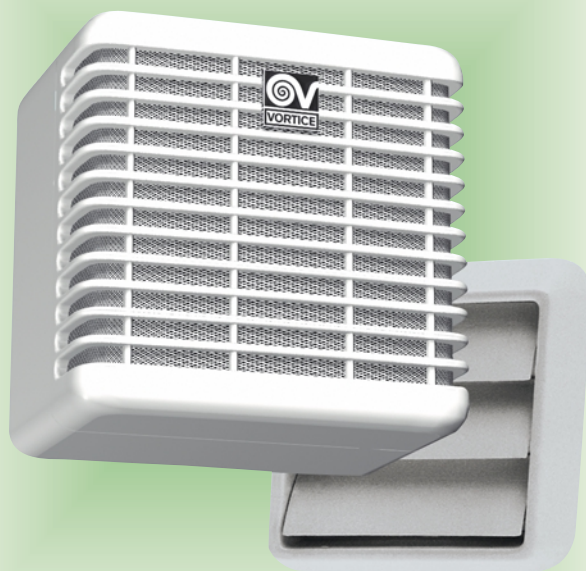

- ① Ducted installation.
- ② Wall or ceiling installation.
- ③ Motor with ball bearings: 30,000 hours guaranteed continuous operation.

Supply and install a Vort Press Habitat centrifugal extract fan with removable, integral backdraught shutter for installation in wall or ceiling and ducted applications as manufactured exclusively by Vortice only for Vortice. The fan should provide continuous trickle ventilation at low speed and have a second boost speed option and comply with the requirements of the Building Regulations (Document F) and the alternative approach 1.9D. The requirements are 15 l/s for bathrooms/toilets/shower rooms and 6 l/s for toilets – alternative approach 1.9D requires 0.5 ACH throughout the dwelling. It should be tested and certified as IPX4 (splashproof) with all performance data third party IMQ (BEAB recognised equivalent) verified. The fan should be manufactured from durable, rigid synthetic resin and have a clip-fix front grille complete with washable metallic filter. The motor should be a stainless steel ball bearing, shielded pole motor (30,000-hour guarantee), and include a thermal cut out device. It should consume 8 Watts per hour, or less, on trickle speed.

Dimensions (mm)

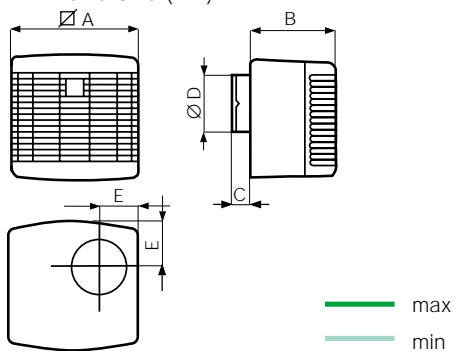

VP Habitat	∅ A	B	C	∅ D	E
30/90	202	147	30	97	73
45/135	275	140	28	97	73

Pressure/performance curves

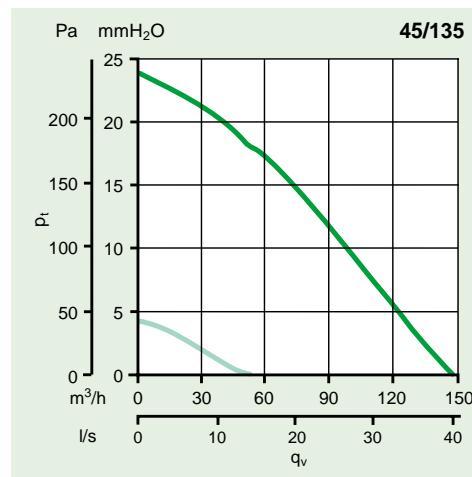
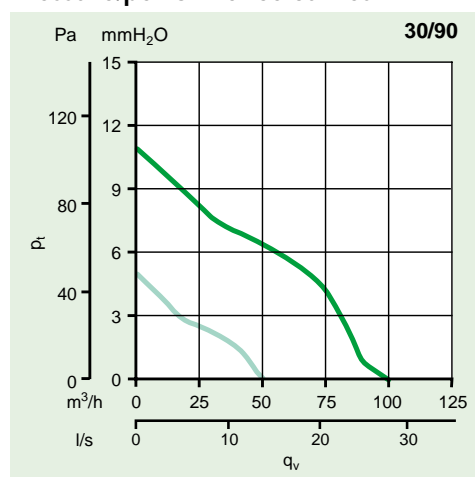

Product	Code	V ~ 50 Hz	W		A		Rpm		Delivery		P max		Lp 1m dB(A)		Approvals	Kg	Insulation	IP
			min	max	min	max	min	max	min	max	min	max	min	max				
Vort Press Habitat LL 30/90	12002	230	8	22	0.06	0.18	820	1450	51 ⁽¹⁾ 14.2 ⁽²⁾	101 ⁽¹⁾ 28.1 ⁽²⁾	4 ⁽¹⁾ 39 ⁽²⁾	14 ⁽¹⁾ 137 ⁽²⁾	28.5	44.5		2.1		X4
Vort Press Habitat LL 45/135	12004	230	4	29	0.04	0.12	430	1170	52 ⁽¹⁾ 14.4 ⁽²⁾	149 ⁽¹⁾ 41.4 ⁽²⁾	5 ⁽¹⁾ 49 ⁽²⁾	23 ⁽¹⁾ 225 ⁽²⁾	26.5	48		2.7		X4

⁽¹⁾ m³/h - ⁽²⁾ l/s - ⁽³⁾ mm H₂O - ⁽⁴⁾ Pa